



Continuous Ink Jet

Videojet® 1630

Engineered for superior uptime in high speed applications. The Videojet 1630 offers greater productivity and low cost of ownership.

Demanding manufacturing facilities require predictable maintenance to maximize uptime and increase profitability. The Videojet 1630 features Long Life Core™ technology that provides five years of operation between planned wear parts replacement, delivering lower cost of ownership for high-speed and around-the-clock applications.⁽¹⁾

Innovative features including patented CleanFlow™ and Dynamic Calibration technology provide increased productivity and superior print quality even at high speeds.



Uptime Advantage

- Long Life Core™ guarantees 5 years continuous operation from point of installation⁽¹⁾
- CleanFlow™ technology resists ink buildup that can cause ordinary ink jet printers to shut down
- Internal pump means no external air, minimizing potential for contaminants to enter ink stream
- Auto cleaning printhead for fast start-ups, even after extended shutdowns

Built-in productivity

- Dynamic Calibration™ adjusts jetting parameters automatically to help ensure high quality print
- Print 1 to 5 lines of print for a range of coding needs
- Smart Cartridge™ fluid delivery system to virtually eliminate spills and help ensure the correct fluids are being used

Code Assurance

- Multiple password protected access levels to system control menus help avoid unintentional input errors
- Storable print messages with pre-set and calculated fields minimize required user input
- Easy Videojet CLARISOFT® and CLARISUITE™ integration allows for remote control of advanced code functionality

Simple usability

- Bright display with WYSIWYG and function keys for easy operation
- Store up to 250 complex messages for easy recall – store even more messages using a standard USB memory stick
- User levels to separate operation from installation and maintenance

⁽¹⁾ Parts-only limited warranty prorated for the remaining life at time of warranty replacement.

Videojet® 1630

Continuous Ink Jet

Line speed capability

Can print 1 to 5 lines of print at speeds of up to 960 ft./min. (293 m/min.) (10 characters per inch, single line of print)

Font matrix configuration

Single-line: 5x5, 4x7, 5x7, 7x9, 9x12, 10x16, 16x24, 25x34
Twin-line: 5x5, 5x7, 7x9, 9x12, 10x16
Tri-line: 5x5, 4x7, 5x7, 7x9
Quad-line: 5x5, 4x7, 5x7
Five-line: 5x5

Linear bar codes

UPC A&E; EAN 8 & 13; Code 128 A, B & C; UCC/EAN 128;
Code 39; Interleaved 2 of 5; 2D DataMatrix; GS1

DataMatrix codes

10x10, 12x12, 14x14, 16x16, 18x18, 20x20, 22x22, 24x24, 16x26,
26x26, 8x32, 32x32, 34x34, 12x36, 16x36, 16x48

Nominal character height

Selectable from 0.079" (2 mm) to 0.40" (10 mm), depending on font

Throw distance

Optimal: 0.472" (12 mm)
Range: 0.197" (5 mm) to 0.591" (15 mm)

Keyboard

Membrane style with tactile feedback, including 72 numeric, alphabetic, and special function keys. PC-style layout to approximate international PC convention.

Display

320x240 Bright blue backlit 5.7" LCD display
WYSIWYG onscreen message editing

Custom logo/graphics

Can be created directly on printer or PC with optional Videojet Logo Creator software

Character sets

Chinese, Russian/Bulgarian, Turkish/Scandinavian, Greek, Arabic,
Japanese/Kanji, Hebrew, Korean, East European and European/American

Languages and interface options

English, German, French, Italian, Spanish, Dutch, Portuguese, Polish, Turkish
Willett Simple Interface (WSI)

Data interface

RS232, RS485 and ethernet (standard)
Clarisoft/Clarinet® via RS232 and ethernet
Message management via USB

Message storage

250 complex messages; unlimited storage using USB

Environmental protection

IP65 standard; no plant air required; stainless steel cabinet

Printhead

Heated printhead
Positive air (standard)
Diameter: 1.63" (41.3 mm)
Length: 10.62" (269.8 mm)

Printhead umbilical

Ultra flexible
Length: 9.84' (3 m) optional 19.69' (6 m)
Diameter: 0.91" (23 mm)
Bend radius: 4.0" (101.6 mm)

Make-up fluid consumption

As low as 2.4 ml per hour

Fluids containers

Ink Smart Cartridge™ 0.793 qt. (750 ml)
Make-up Smart Cartridge 0.793 qt. (750 ml)

Temperature/humidity range

32°F to 122°F (0°C to 50°C)
10% to 90% RH non-condensing
With selected inks; actual installation may require additional hardware based on production environment conditions

Electrical requirements

Nominal supply power 100-120 / 200-240 VAC at 50/60 Hz, 120 W

Approximate weight

Unpacked and dry: 46.2 lbs. (21 kg)

Options

Dry air kit for high humidity (requires plant air)
60 or 70 micron nozzle
90 degree printhead
Wide range of accessories

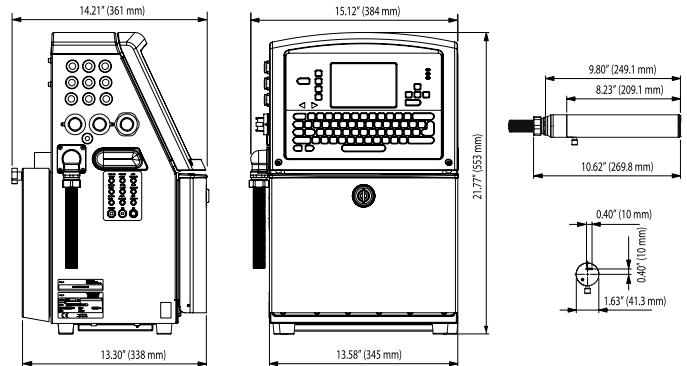

CERTIFIED
ISO 9001
DOCUMENTED QUALITY



Call (65) 6444 4218

Email marketing.singapore@videojet.com

or visit www.videojet.sg

Videojet Technologies (S) Pte Ltd
No. 11 Lorong 3 Toa Payoh
Block B #03-20/21 Jackson Square
Singapore 319579

© 2016 Videojet Technologies Inc. — All rights reserved.

Videojet Technologies Inc.'s policy is one of continued product improvement. We reserve the right to alter design and/or specifications without notice.

Part No. SL000609
1630 Spec Sheet-0816

