

# Automatic Check Weigher FAC-5900 LW-Series

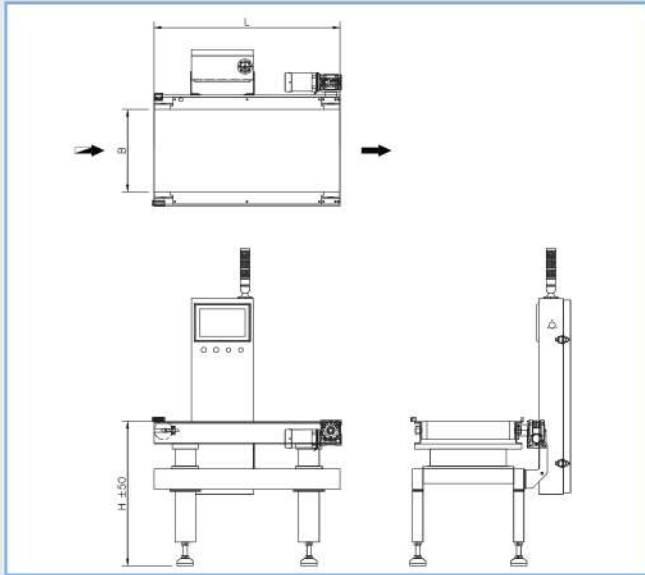

## External Dimensions (unit: mm)

| MODEL         | LW400                           | LW500 | LW600 | LW700 |
|---------------|---------------------------------|-------|-------|-------|
| B(belt width) | 400                             | 500   | 600   | 700   |
| L             | 700, 800, 900, 1000, 1200, 1300 |       |       |       |

## Specifications

| MODEL                             | LW400  | LW500       | LW600       | LW700       |
|-----------------------------------|--|-------------|-------------|-------------|
| 최대용량 (Maximum capacity)           | 20Kg   | 30Kg        | 40Kg        | 60Kg        |
| 계량범위 (Weigh range)                | 200~20,000g  | 300~30,000g | 400~40,000g | 600~60,000g |
| 한눈의 값 (Scale interval)            | 5g   | 10g         | 10g         | 20g         |
| 최대계량확도 (maximum accuracy*)        | ± 15g  | ± 20g       | ± 30g       | ± 40g       |
| 최대처리속도 (Maximum weighing speed**) | 45ea/min   | 35ea/min    | 25ea/min    | 20ea/min    |
| 사용전원(Power requierments)          | 220VAC ± 10%, Single phase, 50/60Hz  |             |             |             |
| 환경조건(Environmental conditions)    | 5 ° C~35 ° C(41 ° F~95 ° F), Variation not to exceed ± 2 ° C(4 ° F)/hr, Relative humidity: 35%~85% |             |             |             |

\* 최대계량확도는 계량물의 상태나 조건에 따라 달라질 수 있습니다.

\*\* 최대 처리속도는 계량물의 크기나 컨베이어의 속도에 따라 달라질 수 있습니다.

\* Maximum accuracy may change depending on the product conditions.

\*\* Maximum weighing speed may change depending on the product dimension and conveyor speed.

**Công ty Cổ phần Ân Hồng**

Địa chỉ: Số 176 Vạn Phúc, Hà Đông, Hà Nội

Hotline Tư vấn thiết bị: 0901 771 699

Email: info@anhong.com.vn

Website: www.anhong.com.vn

